

## Wall Pack Series

### Small Accord Semi-Cutoff Wall Pack



**WPA15**

#### Housing:

Die Cast Aluminum Housing & Hinged Front Frame with Stainless Steel Hinge Pins, 1/2" Coin Plugs with O-rings for Conduit & Photocell, Textured Architectural Bronze Powdercoat Finish Over a Chromate Conversion Coating, Includes Safety Cable to Prevent Front Frame Impact When Relamping

#### Reflector:

Aluminum Reflector

#### Lens:

Prismatic Borosilicate Glass Lens

#### Socket:

HID: Porcelain 4KV Pulse Rated Medium Base Socket with Nickel Plated Screw Shell

PL: Plug-In Type, GX24Q-4

#### Mounting:

Cast-in Template for Mounting Directly Over a 4" Recessed Outlet Box, or Use 1/2" Surface Conduit.

#### Wattage:

High Pressure Sodium: 35 to 150w

Metal Halide: 50 to 100w

Pulse Start: 150w

Compact Fluorescent: 1 x 26 to 42w,

2 x 26 to 42w

#### Listing & Ratings:

CSA: Listed for Wet Locations

**Add:** P18110 120V Pencil Photocell

P18120 120V Swivel Photocell

P18112 240V Pencil Photocell

P18122 240V Swivel Photocell

(Photocells Are Field Installed)

Other Wattages & Custom Colors Available Upon Request.

**KELSEY-KANE LIGHTING MFG. CO.**

Voice & Text: 954-772-3187

E-Mail: [info@kelsey-kane.com](mailto:info@kelsey-kane.com)

Website: [www.kelsey-kane.com](http://www.kelsey-kane.com)

Kit(s)				
Catalog #	Description			
WPA15	Small Accord Semi-Cutoff Wall Pack, HID Kit			
WPA15F	Small Accord Semi-Cutoff Wall Pack, Single Fluorescent Kit			
WPA15F2	Small Accord Semi-Cutoff Wall Pack, Twin Fluorescent Kit			
Complete Units (Lamp Included)				
Catalog #	Wattage	Voltage	Lamp	Ballast
WPA15H35R120L	35	120	HPS	R-NPF
WPA15H50R120L	50	120	HPS	R-NPF
WPA15H70R120L	70	120	HPS	R-NPF
WPA15H100R120L	100	120	HPS	R-NPF
WPA15H150R120L	150	120	HPS	R-NPF
WPA15H50DL	50	120/277	HPS	HX-HPF
WPA15H70QL	70	Quad	HPS	HX-HPF
WPA15H100QL	100	Quad	HPS	HX-HPF
WPA15H150QL	150	Quad	HPS	HX-HPF
WPA15M50DL	50	120/277	MH	HX-HPF
WPA15M70QL	70	Quad	MH	HX-HPF
WPA15M100QL	100	Quad	MH	HX-HPF
WPA15P150QL	150	Quad	PS	HX-HPF
WPA15F26EL	1 x 26	120-277	PL	Electronic
WPA15F32EL	1 x 32	120-277	PL	Electronic
WPA15F42EL	1 x 42	120-277	PL	Electronic
WPA15F52EL	2 x 26	120-277	PL	Electronic
WPA15F64EL	2 x 32	120-277	PL	Electronic
WPA15F84EL	2 x 42	120-277	PL	Electronic

**DIMENSIONS**

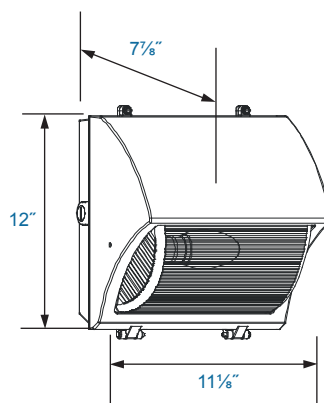

**WPA15**

Catalog #	Description
WPA15WG	Wire Guard for WPA15
3EB120277	Battery Backup Pack, 120-277V

**Wall Pack Series**

**Small Accord Semi-Cutoff Wall Pack**



**WPA15WG**



**3EB120277**

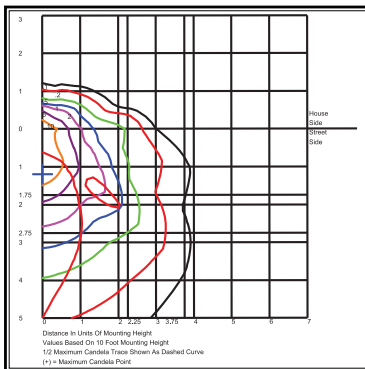

**WPA15P150**

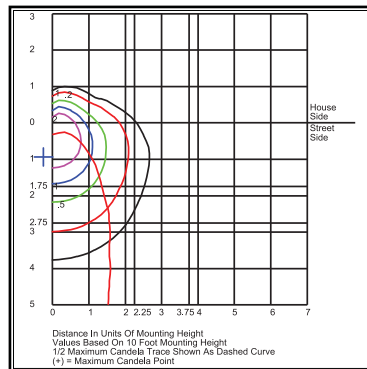

**WPA15F84EL**

**KELSEY-KANE LIGHTING MFG. CO.**  
 Voice & Text: 954-772-3187  
 E-Mail: info@kelsey-kane.com  
 Website: www.kelsey-kane.com